

# SHB

## Series Ultra-Low Headroom Chain Hoist

### 1 to 10 metric tonne capacity, steel body hoist

This ultra-low headroom trolley hoist offers premium quality and durability in a low profile package. With Kito's SHB Hand Chain Hoist, the built-in geared trolley configuration minimizes beam-to-hook distance making it ideal for applications where longer hook travel is required. This hoist is ideal for demanding industrial lifting applications where space is limited.



#### FEATURES

- » Headroom as low as 4.5"
- » Durable all-steel construction
- » Efficient drive train minimizes effort required to operate
- » Trolley wheels fit on both tapered and flat flanged beams
- » Maintenance-free sealed trolley ball bearings are "lubed-for-life" and offer smooth movement
- » Reliable hoist braking with double-enclosed brake cover that keeps out moisture, dust, and dirt
- » Grade 100 heat-treated alloy load chain resists abrasion and wear
- » Cast trolley wheels and steel side plates allow for heavy-duty applications
- » 20' standard lift - Longer lengths are available

#### STANDARDS

- » ASME B30.16 Safety Standard
- » ASME HST-2 Performance Standard
- » 125% of rated capacity test load
- » Grade 100 Chain

#### OPTIONS

- » Corrosion resistant chain for tough environments
- » Custom lift lengths to suit your requirements

#### COMPARE

SHB vs. M3CB Headroom comparison

Capacity (tonne)	SHB		vs	M3CB		Difference (in)
	Model	Headroom (in)		Model	Headroom (in)	
1	SHB010	4.5		CBSG010	12	-7.5
2	SHB020	5.7		CBSG020	15	-9.3
3	SHB030	6.5		CBSG030	21	-14.5
5	SHB050	7.7		CBSG050	26	-18.3
10	SHB100	10.0		CBSG100	34	-24.0

Headroom  
as low as  
**4.5"**

**KITO**

**WWW.KITO.CA | 1 888 322 KITO (5486)**

All specifications, dimensions and drawings are available at [www.kito.ca](http://www.kito.ca), or call our Customer Service staff for friendly and expert advice on models and options.

PRINTED IN CANADA | SHB - ENG - 12

# SHB 1 to 10 metric tonne

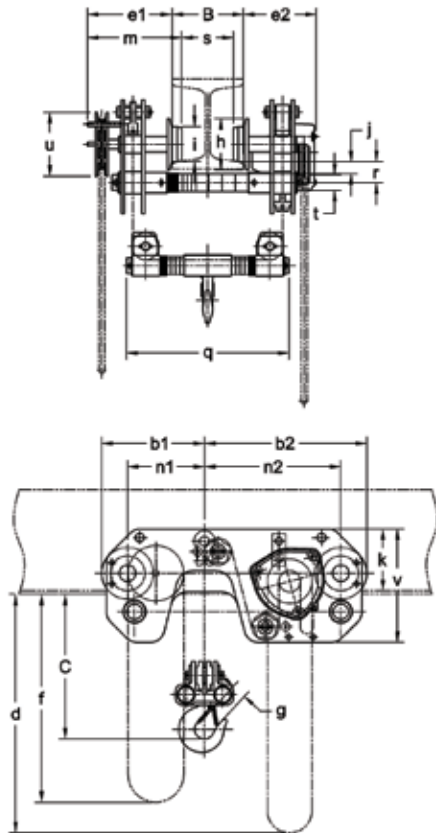

## DIMENSIONS (in)

Capacity (tonne)	Model	b1 (in)	b2 (in)	d (in)	e1 (in)	e2 (in)	f (in)	g (in)	h (in)	i (in)	j (in)	k (in)	m (in)	n1 (in)	n2 (in)	q (in)	r (in)	s (in)	t (in)	u (in)	v (in)
1	SHB010	8.0	13.5	19.3	7.9	7.0	19.3	1.1	4.2	2.8	1.0	4.5	8.7	5.9	11.4	14.6	1.8	B-1.6	1.2		9.6
2	SHB020	9.6	15.7	19.0	8.9	7.6	19.0	1.4	5.0	3.4	1.2	6.6	9.9	7.1	13.2	17.3	2.1	B-2.0	1.4	6.0	11.4
3	SHB030	11.6	18.3		9.5	8.1		1.7	5.8	3.9	1.3	7.0	10.6	8.7	15.4	18.3	2.4	B-2.2	1.7	7.2	12.8
5	SHB050	13.8	21.3	10.5	8.8	1.8	6.7	4.7	1.4	8.8	11.9	10.4	17.9	19.5	2.8	B-2.9	2.2			15.4	
10	SHB100	15.5	23.1	11.4	8.5	2.4	7.3	6.1	1.3	10.5	13.2	11.8	19.4	19.6	3.3	B-3.5	2.8			8.4	16.5

## SPECIFICATIONS

Capacity (tonne)	Model	Standard Lift (ft)	Headroom (in)	Hand Pull to Lift Full Load (kg)	Standard Flange Width (in)	Load Chain Code	Load Chain Falls	Ship Weight (lbs)	Weight per 5 ft of Lift (lbs)
1	SHB010	20	4.5	29	2.3-6.4	KCF050	2	176	10
2	SHB020	20	5.7	26	3.2-8.0	KCF071	2	281	14
3	SHB030	20	6.5	34	3.2-8.0	KCB3080	2	395	16
5	SHB050	20	7.7	41	3.9-8.0	KCB3090	2	665	19
10	SHB100	20	10.0	44	5.5-8.6	KCB3090	4	868	31



[WWW.KITO.CA](http://WWW.KITO.CA) | 1 888 322 KITO (5486)

PRINTED IN CANADA | SHB - ENG - 12

All specifications, dimensions and drawings are available at [www.kito.ca](http://www.kito.ca), or call our Customer Service staff for friendly and expert advice on models and options.